

**PROPRIETARY AND CONFIDENTIAL**  
 THE INFORMATION CONTAINED IN THIS DRAWING IS THE SOLE PROPERTY OF Marra Forni ANY REPRODUCTION IN PART OR AS A WHOLE WITHOUT THE WRITTEN PERMISSION OF Marra Forni IS PROHIBITED.

		UNLESS OTHERWISE SPECIFIED:		NAME	DATE
		DIMENSIONS ARE IN INCHES		DRAWN	
		TOLERANCES:		CHECKED	
		FRACTIONAL ±		ENG APPR.	
		ANGULAR: MACH ±0.50 BEND ±1.0		MFG APPR.	
		TWO PLACE DECIMAL ±.03		Q.A.	
		THREE PLACE DECIMAL ±.01		COMMENTS:	
		INTERPRET GEOMETRIC TOLERANCING PER: ASME Y14.5-2009			
		MATERIAL			
NEXT ASSY	USED ON	FINISH			
APPLICATION		DO NOT SCALE DRAWING			
TITLE:			SIZE	DWG. NO.	REV
			<b>B</b>	ELST 3736-1	<b>A</b>
SCALE: 1:3			WEIGHT:	SHEET 1 OF 2	

8 7 6 5 4 3 2 1

D  
C  
B  
A

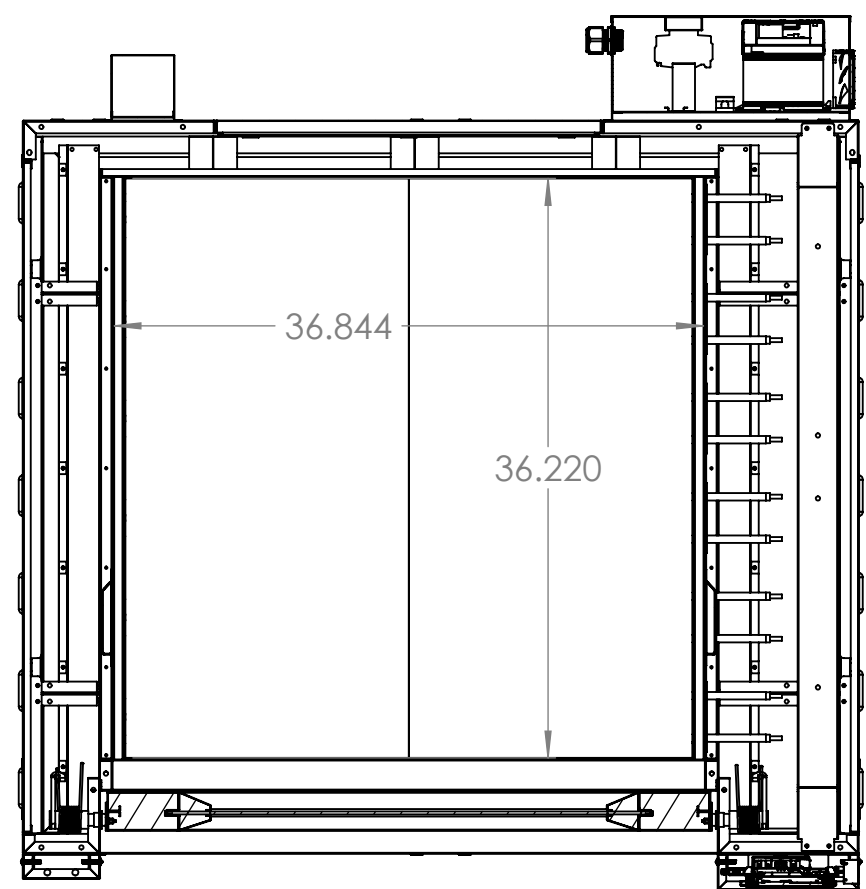
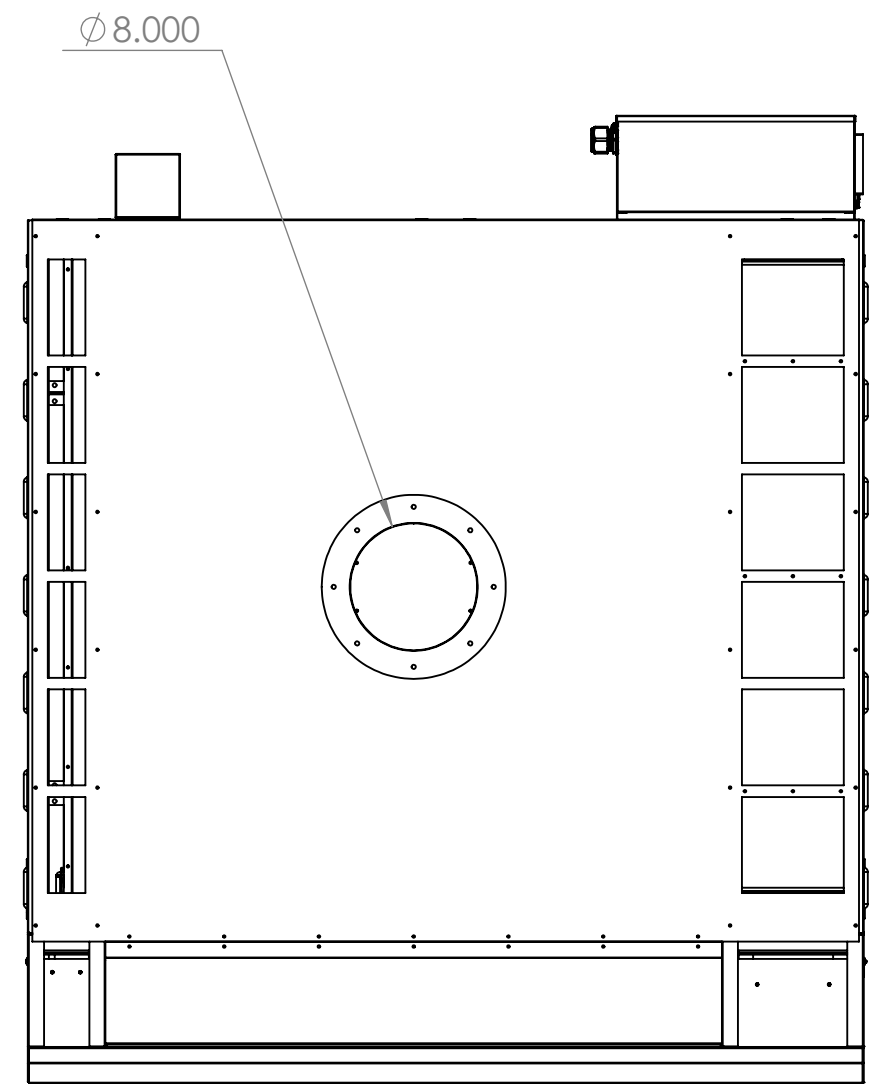

**SECTION A-A**  
SCALE 1 : 12

**PROPRIETARY AND CONFIDENTIAL**  
THE INFORMATION CONTAINED IN THIS DRAWING IS THE SOLE PROPERTY OF Marra Forni ANY REPRODUCTION IN PART OR AS A WHOLE WITHOUT THE WRITTEN PERMISSION OF Marra Forni IS PROHIBITED.

		UNLESS OTHERWISE SPECIFIED:		NAME	DATE	TITLE:
		DIMENSIONS ARE IN INCHES		DRAWN		
		TOLERANCES:		CHECKED		
		FRACTIONAL ±		ENG APPR.		
		ANGULAR: MACH ±0.50 BEND ±1.0		MFG APPR.		
		TWO PLACE DECIMAL ±.03		Q.A.		SIZE <b>B</b> DWG. NO. ELST 3736-1 REV <b>A</b>
		THREE PLACE DECIMAL ±.01		COMMENTS:		
		INTERPRET GEOMETRIC TOLERANCING PER:ASME Y14.5-2009				SCALE: 1:3 WEIGHT: SHEET 2 OF 2
		MATERIAL				
NEXT ASSY	USED ON	FINISH				
APPLICATION		DO NOT SCALE DRAWING				

8 7 6 5 4 3 2 1